

ELMDENE

Protecting People & Property

Elmdene International Ltd
3 Keel Close, Interchange Park,
Portsmouth, Hampshire, PO3 5QD, UK

Tel: +44(0)23 9269 6638
Fax: +44(0)23 9266 0483
Web: www.elmdene.co.uk

13.8Vdc Switch Mode Power Supply

GEN3-08-y[#] for 8Ah Battery and up to 1.0A* Continuous Load Current

GEN3-18-y[#] for 18Ah Battery and up to 1.5A* Continuous Load Current

FEATURES

High efficiency cost effective power supply suitable for use in systems designed to comply with PD6662:2010 and EN50131-6:2008 Grade 3 and Environmental Class II. Rated to provide **continuous current to load** for systems requiring 12h standby from a battery. Three independent output signals are provided for loss of mains fault (EPS**), battery fault (APS**), and power supply fault (GEN). Comprehensive self-diagnostics can detect blown output and battery fuses, battery fail, low battery voltage, battery missing and low output voltage. The PSU incorporates intelligent battery management comprising active full load battery testing, low battery voltage detection and deep discharge protection to ensure that the battery is not permanently damaged through excessive discharge. A brownout filter ensures that short mains voltage dips do not create a false loss of mains alarm. Two LEDs assist with quick and easy installation by showing presence of mains, correct battery charging or a fault condition. Comprehensive protection is built-in as standard including mains transient filtering, electronic output overload protection and fuses on the load and battery outputs.

- PD662:2010 and EN50131-6:2008 Type A Grade 3 Environmental Class II Compliant
- Intelligent active battery monitoring
- Low quiescent battery monitoring current during standby operation
- Fault signals for loss of mains, battery fail and power supply fault
- Battery deep discharge protection
- Battery overvoltage protection
- Protection against reverse battery connection
- Electronic overload protection shuts down output until overload or short circuit is removed (while on mains power)
- LED for comprehensive diagnostics
- Mains transient suppression and brown-out filter
- Fully enclosed lid and removal from wall tamper circuit.

[#] "y" Denotes enclosure size – see overleaf

* See table overleaf to determine continuous standby battery current available for given standby times

**EN50131 Definitions: EPS = External Power Source APS = Alternative Power Source

SPECIFICATION
Mains Input

Rated Voltage / (Operational Voltage)	100-240Vac / (90 – 265Vac)
Frequency	50/60Hz
Input current	GEN3-08 & GEN3-18 < 1.0A at full load
Fuse	T2A 20mm HRC

Output

	GEN3-08-y	GEN3-18-y
Voltage at full load		
Mains power	13.2 –14.2Vdc (13.8Vdc nominal)	
Battery standby	9.8 – 13.0Vdc	
Ripple	<400mV pk – pk max @ Rated Voltage	
Fuse:		
Load	F1.0A	F1.6A
Battery	F1.0A	F1.6A
Continuous Output Current*		
Mains	1.0 A	1.5A
Battery for 12 hours	0.60A with 8Ah Battery	1.5A with 18Ah Battery
30 hours	0.26A with 8Ah Battery	0.6A with 18Ah Battery
60 hours	0.13A with 8Ah Battery	0.3A with 18Ah Battery

*See below for quiescent current of PSU under battery when calculating total system standby current resources.

Mechanical

Product Reference	GEN3-08-A	GEN3-08-B GEN3-18-B	GEN3-08-C GEN3-18-C
Enclosure Dimensions w x h x d (mm)	230 x 200 x 80	355 x 330 x 80	330x 275 x 80
Weight (kg) excluding battery	2.0	4.0	3.3
Material	1.2mm steel white powder coated		

Environmental

Temperature	-10 to +40°C (operating) 75% RH non-condensing -20 to +80°C (storage)
-------------	--

Standby Battery Management

Maximum Battery Size (Not supplied with unit)	Warning: risk of explosion if incorrect battery type fitted GEN3-08: 8 Ah 12V Valve Regulated Lead Acid GEN3-18: 18Ah 12V Valve Regulated Lead Acid
Intelligent Battery Recharge Time:	< 24 hours to 80% - A heavily discharged battery having a terminal voltage > 9.0V will attempt to be charged. If battery fails to accept charge in 24 hours it will fail the active load test.
Testing:	Battery not Present: <9.0V battery voltage Low battery voltage: <11.6V (no mains present) Active load test at full rated output current
Protection:	Reverse battery connection protection Overvoltage protection - Trips at 125% of rated O/P voltage Deep discharge protection - Battery disconnect at 10.5V battery terminal voltage
Quiescent Current:	64mA when running on battery - less than 1mA after deep discharge protection.
Battery Cold Start (BCS)	Momentarily link BCS pins together to connect battery to load if PSU commissioned without any mains

SIGNALLING OUTPUTS

Rating:	0.10A @ 60Vdc 16Ω solid state relay contacts, volt free.
EPS Fault:	Open if Loss of mains for >8s
GEN Fault:	Open if Output voltage < 9.0V, or Output short circuit, or Output fuse blown
APS Fault:	Open if Battery terminal voltage < 11.6V, or Active Battery Monitoring detects a failed battery, battery fuse blown or battery not present.
Tamper:	0.5A @ 30Vdc volt free contact. Open when lid is open or unit removed from mounting surface.

CONNECTIONS

O/P +, -	Connection to equipment to be powered (Observe polarity)
EPS (FAULT)	Relay output for mains fail. Open if loss of mains.
GEN (FAULT)	Relay output for General Fault. Open in fault condition
BATT +, -	Connection to standby battery. Use cables provided (Observe polarity)
APS (FAULT)	Relay output for battery fail. Open if battery fail or low voltage

INSTALLATION AND COMMISSIONING

This unit is only suitable for installation as permanently connected equipment. This PSU is *NOT SUITABLE* for external installation. *EQUIPMENT MUST BE EARTHED*. Before installation, ensure that external disconnect device is *OFF*. The PSU should be installed according to all relevant safety regulations applicable to the application.

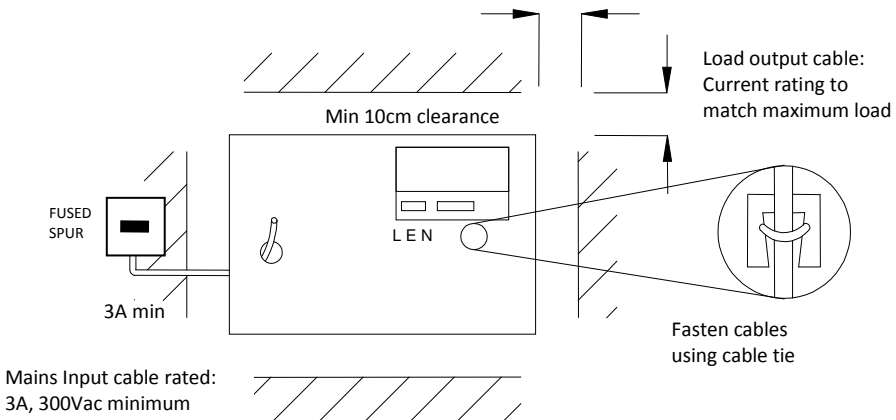

Fig 1 Mounting of Power Supply

Mounting

- 1) Site power supply unit allowing minimum clearance – see Fig. 1.0
- 2) Ensure that the rear tamper is not in a position that will affect its operation, for example over a mortar course, recess or raised area on the wall.
- 3) Route mains and LV output cables via different knockouts and/or cable entry holes.
- 4) Use bushes and cable glands rated to UL94 HB minimum.

Mains Power Up

- 5) Attach correctly rated mains cable (minimum 0.5mm^2 [3A], 300/500Vac). Fasten with cable ties.
- 6) Apply mains power.
Check for 13.8V on load outputs.
Check green Mains LED is ON.
- 7) Disconnect mains power.

Load Output

- 8) Loop correctly rated load cable through supplied ferrite (1 turn) and attach to terminal block, note polarity. Fasten with cable ties.

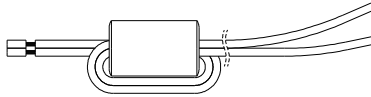

Fig 2 Position of ferrite

- 9) Apply mains power.
Check Green Mains LED is ON.
NOTE: Red Fault LED may flash to indicate no battery has been connected, this is normal, refer to diagnostic table on page 7.
Verify load is operating correctly.
- 10) Disconnect mains power.

Signalling

- 11) Connect EPS, APS and GEN fault outputs to appropriate inputs of control and indicating equipment (CIE).

Standby Battery

- 12) Attach supplied battery cables to terminal block and batteries.
NOTE: ensure correct polarity of battery connections: **+ve** use **Red** lead, **-ve** use **Black** lead.
- 13) Position the battery as shown in Figures 3 - 7 below, avoiding the cover earth connection spades and the cover retaining screws. Fold up 'Tabs' to locate battery and secure with the rubber band supplied.

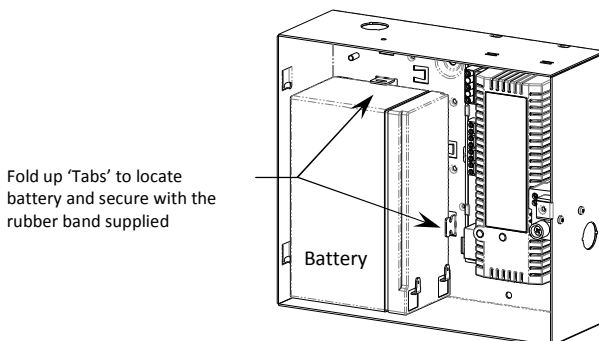
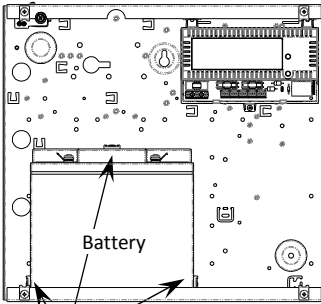
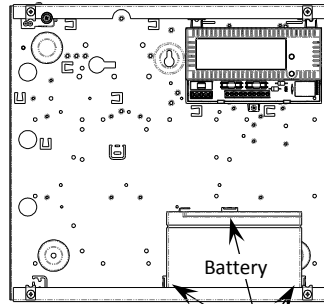

Fig 3 GEN3-08-A



Fold up 'Tabs' to locate battery and secure with the rubber band supplied

Fig 4 GEN3-18-B



Fold up 'Tabs' to locate battery and secure with the rubber band supplied

Fig 5 GEN3-08-B

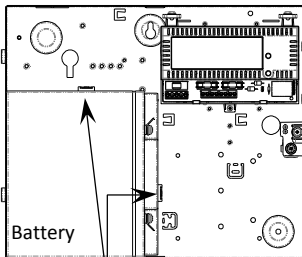

Fold up 'Tabs' to locate battery and secure with the rubber band supplied

Fig 6 GEN3-18-C

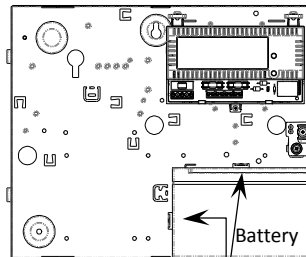

Fold up 'Tabs' to locate battery and secure with the rubber band supplied

Fig 7 GEN3-08-C

- 14) Apply mains power.
Check that Green Mains LED is ON.
Check there is no fault indicated by the Red Fault LED, refer to diagnostic table on page 7.
- 15) Disconnect mains power.
Check that the battery continues to supply voltage and current to the output load.
Check that Green Mains LED is OFF and the control panel displays a Loss of Mains (EPS) fault
NOTE: The battery must have sufficient charge to supply the output load
- 16) Reconnect mains power.
Check that Green LED is ON.
- 17) Disconnect battery.
Check that Red Fault LED is indicating a fault, refer to diagnostic table on page 7, and that the control panel is showing an APS fault.
- 18) Reconnect battery.
Check there is no fault indicated by the Red Fault LED, refer to diagnostic table on page 7, and that the control panel is not showing an APS fault.
- 19) Remove Output fuse.
Check that Red Fault LED is indicating a fault, refer to diagnostic table on page 7, and that the control panel shows a General PSU fault.
- 20) Replace Output fuse.
Check that Red Fault LED is OFF
Check that EPS, APS and GEN Fault signals (if connected) are cleared at the control panel.

Tamper

21) Connect tamper switch to appropriate inputs of control and indicating equipment (CIE).

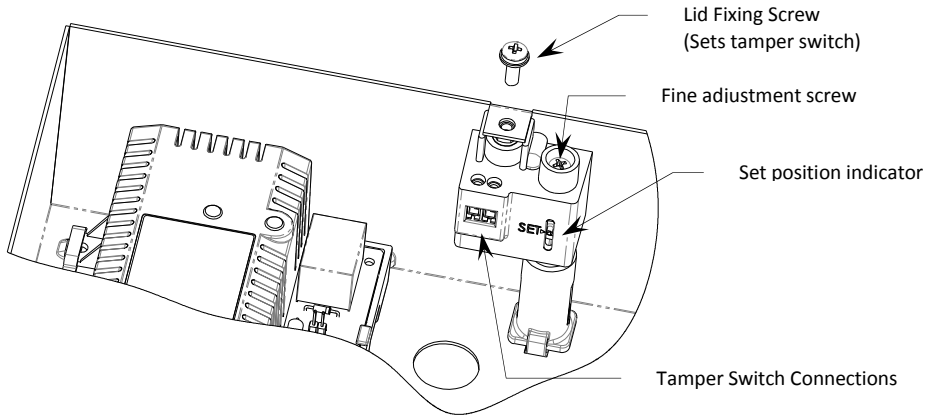

Fig 8 Position of tamper assembly on 'hinged lid' style enclosures

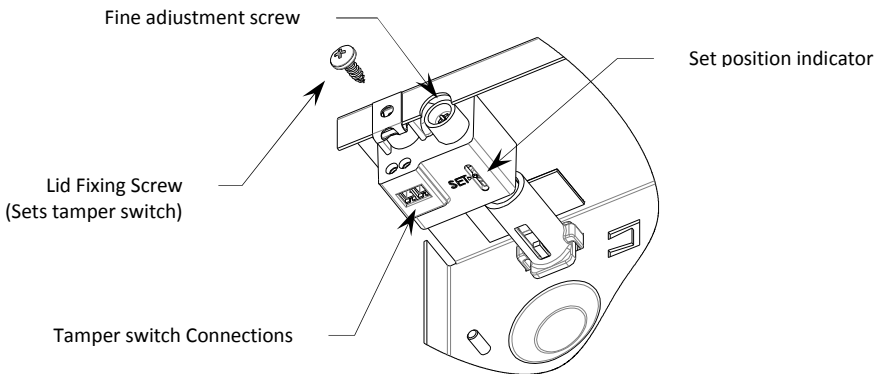

Fig 9 Position of tamper assembly on 'clam shell' style enclosures

- 22) Close the lid and fasten with screw supplied. Alternatively for 'clam shell' style fit the cover in place, the correct orientation is with the cover retaining feature engaging over the bottom lip of the base, fasten with screws supplied.
- 23) With the unit mounted on the wall check that the rear tamper is not in a position that will affect its operation, for example over a mortar course, recess or raised area on the wall.
Check that the tamper switch is:
CLOSED when the lid/cover is closed and the retaining screws are fitted,
OPEN when the retaining screws are removed and the lid/cover is open.
Use fine adjustment screw if necessary to align indicator with set point.
- 24) Close the lid/cover and fasten.
- 25) Re-check tamper circuit is closed at the control panel.

OPERATING INSTRUCTIONS

In the event of loss of mains, a battery fault or a GEN fault, the corresponding Fault signal contacts will open. If the output of the PSU fails, the cause of the failure should be investigated e.g. short circuit load, connection of a deeply discharged battery. The fault should be rectified before restoring power to the PSU. If any of the fuses require replacing, ensure the correct fuse rating and type is used.

MAINTENANCE

This unit is intended for use by Service Personnel only. There are NO USER SERVICEABLE parts inside. There is no regular maintenance required of the PSU other than periodic testing, and replacement of the standby battery. **Reference should be made to the battery manufacturer's documentation to determine typical/expected battery life with a view to periodic replacement of the battery.**

DIAGNOSTICS

Local Diagnostics

Green LED

On = Mains Present

Red LED

Fault Diagnostics according to table:

Red LED (fault)	Green LED (mains)	Status
OFF	ON	Normal: Battery fully charged
One short flash every second	ON	Normal: Battery charging but not fully charged
Flashing: 1second On 1 second Off	ON	Fault: Output fuse or battery fuse blown, or battery/PSU fault
	OFF	Fault: No mains, output fuse blown
One short flash every 3 seconds	OFF	Fault: No mains, battery supplying load.
OFF	OFF	Fault: No mains, No output, battery disconnected or completely discharged

COMPLIANCE

This power supply unit meets the essential requirements of the following EU Directives:

EMC: 2014/30/EU

Low Voltage: 2014/35/EU

WEEE: 2012/19/EU

RoHS2: 2011/65/EU

This product is suitable for use in systems designed to comply with PD6662:2010 at Grade 3 and Environmental Class II

EN50131-6:2008

Type A Security Grade 3
Environmental Class II

Certification Body:

Telefication B.V.
Edisonstraat 12A
Zevenaar, 6902 PK
The Netherlands
+31 (0) 316 - 583 180
<http://www.telefication.com>



DISPOSAL OF PRODUCT AT END OF LIFE

This product falls within the scope of EU Directives 2012/19/EU Waste Electrical and Electronic Equipment (WEEE) and 2013/56/EU (Battery). At the end of life, the product must be separated from the domestic waste stream and disposed via an appropriate approved WEEE disposal route in accordance with all national and local regulations.

Before disposal of the product, any batteries must be removed, and disposed separately via an appropriate approved battery disposal route in accordance with all national and local regulations. Package used batteries safely for onward transport to your supplier, collection point or disposal facility.

**Caution: Risk of fire or explosion
if bare battery wires are allowed to touch.**

See Specification for battery type information. The battery is marked with the crossed out wheelee bin symbol, which may include lettering to indicate cadmium (Cd), lead (Pb), or mercury (Hg).

For more information see: www.recyclethis.info

*The packaging supplied with this product may be recycled.
Please dispose of packaging accordingly.*

Explanation of symbols: (Not all may apply)

Fault Indication



Shock Risk - isolate before attempting access



Mains Present



Certification Level



Protective Earth



Do not dispose of in unsorted waste

Specifications subject to change without notice