

Security Radar



ENGLISH

Diagram References

1 Indicator

- a. Power Supply Indicator
Solid Green: Detector Power on
- b. Fault Alarm Indicator
Flashing Red: Fault Alarm Occurred, Solid Green: Alarm Restored
- c. Zone Alarm Indicator
Solid Red: Zone Alarm Occurred, Solid Green: Alarm Restored
- d. Formatting Indicator
Red and green LED flashes 3 times: Formatting Successfully

2 Formatting

Loosen the screws on the rear cover to remove the cover. Hold the Reset button while powering the radar on until the red and green LED flashes 3 times.

3 Wiring

- a. Alarm Output Wiring (Dry Contact Output)
a1: one for electrical load
a2: three for electronic load
- b. Alarm Input Wiring (Reserved)
- c. DC Power Supply Wiring
- d. Ethernet (PoE port) Wiring
- e. Grounding

4 Installation

Before You Start:

- The recommended installation height is 2.5 m.
- Make sure that the mounting surface is strong enough to withstand at least 50N, as well as four times the weight of the device and the bracket.

1 Ceiling Mounting

1. Attach the mounting bracket on the detector with four supplied screws.
2. Loosen the screws on both sides of the bracket.
3. Adjust the angle of the detector.
4. Tighten the screws on the both sides of the bracket to complete the installation.

2 Pole Mounting

1. Attach the mounting bracket on the detector with four supplied screws.
2. Loosen the screws on both sides of the bracket.
3. Adjust the angle of the detector.
4. Tighten the screws on the both sides of the bracket to complete the installation.

5 Test

Test the radar after installation to make sure it is properly mounted. Power on the radar and make sure there is no large object in the monitoring area. Make the detector access into the internet.

1. Download and install the iVMS-4200 client software.
2. Enter **Control Panel - Modules Customization**, select **Radar**, and click **OK**.
3. Enter **Device Management** page, select the radar in the Online Device List, click **Modify NetInfo**, change the port as 80, and click **Add to Client**. If the network of the radar is not the same as the PC's, click **Add** in the Device for Management list and enter the radar IP address in the pop-up window to add the radar.

Note: You should activate the device for the first usage. Select the device in the Online Device List, click **Activate**, create a password to activate the device. Scan the QR code to get the *User Manual of Security Radar*.

4. In iVMS-4200 client software, enter **Control Panel - Radar**.

5. Upload Map: Select a map, draw a path on the map and set the plotting scale.
6. Expand the device group in the list on the left, and click and drag the radar onto the map.
7. Move along the edge of the required monitoring field. Make sure the target sign (red arrow) is moving within the radar area (gray sector) shown on the added map. If the target sign is not within the sector, you need to adjust the mounting position or angle of the radar.

6 Set Up

1 Add Zone or Trigger Line for the Detector

1. In iVMS-4200 client software, enter **Control Panel - Radar**.
2. Click **---** Draw Zone Manually or Draw Trigger Line, and click the mouse to draw a zone or trigger line on the radar detection area.
3. Set the parameters of the zone or trigger line.
Zone: edit the zone parameters in the pop-up window. Click **OK** to finish the settings.
Trigger Line: set the direction of the line (left to right, right to left, or both way). Click **Cancel** to finish the settings.

Note: The trigger line is not allowed to be crossed.

2 Link the camera to the Zone

Before the operation, you need to click the on the **Radar** page or right click the selected radar and select **disarm** to disarm the radar.

1. In iVMS-4200 client software, select the radar on Device Management page and click **Remote Configuration** to enter the configuration page. You can also enter the device IP address in the web browser to enter the configuration page.
2. Click **Smart Rule Settings - Camera Linkage Settings**.
3. Click **+** to add cameras to the radar.
4. Select a camera in the Camera IP Address List, and select the radar zone or the trigger line (or whole field) in the Zone Linkage list or the Trigger Line List.
5. Add the camera to iVMS-4200 client software: In the client software, enter Device Management page, click **Add** in the Device for Management list, and enter the IP address, user name and password of the camera in the pop-up window.

3 Calibrate the Speed Dome

Before the operation, you need to disable the parking function, and set the initial position of the speed dome.

a Initial Position settings

Before calibration, set the initial position of the speed dome to ensure the tracking accuracy.

1. Select a reference object about 50 m away from the speed dome. On the reference object, select a point whose altitude is the same as the speed dome's.
2. Enter the IP address of the speed dome in the web browser to enter the web client. Adjust the PTZ buttons on the Live View page to make the reference object displayed in the image, and click to zoom in the reference object.
3. Click , and click the reference point to middle the point in the frame.
4. Enter **Configuration - PTZ - Initial Position**, and click **Set** to set the initial position.

b Calibration

If the speed dome is installed together with the radar, select the calibration mode as **One Point Calibration**. Otherwise, set the calibration as **Multi-point Calibration**.

For one point calibration, you can refer to the following steps, and see user manual for multi-point calibration.

1. In iVMS-4200 client software, enter Radar page, click **---** **Master-Slave Tracking Settings**.
2. Double click the radar in the list on the left. Click the live view window of the speed dome needs to be calibrated, and click to maximum the window.
3. Select **One Point Calibration** as the calibration mode.
4. Ask the calibration staff to move in the radar detection field. Click the track of the calibrate staff, and the color of the selected track will change from red to white.
5. Click **Add** to add a calibration point.
6. Ask the calibration staff to stand at the calibration point within 20 to 40 m directly in front of the radar.
Note: The track disappears if the calibration staff is standing in place for more than 7 s. If the calibration staff does not move to the calibration point when the track disappears, you need to ask the calibration staff moves again, and click the track of the calibration staff to continue the calibration.
7. Click the added calibration point in the list on the right to update the radar position of the calibration staff.
8. Adjust the PTZ buttons in the live view window to update the PTZ position: Click **-** to scale the calibration staff to a fit size (The altitude of the calibration staff is about 2/3 of the altitude of the window), and adjust the PTZ to make the object align with the sign **+** at the center of the frame. (For precise alignment, click , and click on the center of the calibration staff.)

4 Enable Speed Dome Tracking

In iVMS-4200 client software, enter the Master-Slave Tracking Settings page, select the live view window of the speed dome, and Check **Enable Tracking**.
For detailed settings, Scan the QR code to get the *User Manual of Security Radar*.

Specification

Product	Security Radar	Network Interface	1 RMS 10M/100M self-adaptive, supports POE
Detection Range	Vehicle:150 m, Human:120 m	Communication Protocol	Standard ISAPI protocol, NAL2300
Horizontal Angle	120°	Protocol	HTTP, DNS, NTP, TCP, UDP, DHCP, ARP, and SSH
Zone	16	Exception Detection	Tampering alarm
Trigger Line	4	Power Interface	Moving alarm
Velocity Range	-9.8 to 9.8 m/s	Operation Temperature	802.3at standard POE or 12 VDC The supplied power adapter is for 12 VDC power input.
Range Measurement Accuracy	±0.75 m	Operation Humidity	10% to 90%
Velocity Measurement Accuracy	±0.1 m/s	Dimension(W x H x D)	206-228-61 mm
Angle Measurement Accuracy	±1°	Protection level	IP67, IK09, NEMA 4X
Max. Target Number	64	Weight	1.9 kg
Alarm Output	3-ch weak current output: 0.5 A/125 VAC, breakdown voltage: 1 KV 1-ch strong current output: 10 A/240 VAC, breakdown voltage: 2.5 KV	Installation	Bracket installation Installation Height: 1.2 m to 4 m Recommended height range: 2.5 m Recommended vertical angle: 0°

Use only power supply listed below:
Manufacturer: Shenzhen HONOR Electronic Co., Ltd.
Model: ADS-26FSG-12 12024EPG

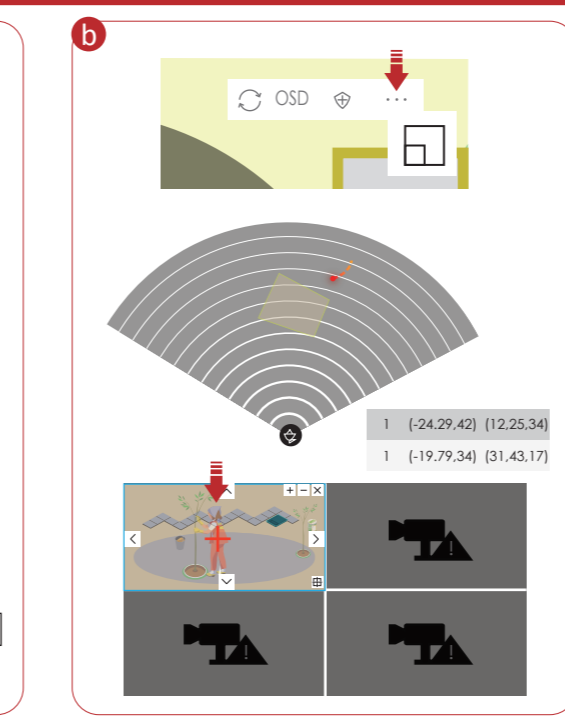
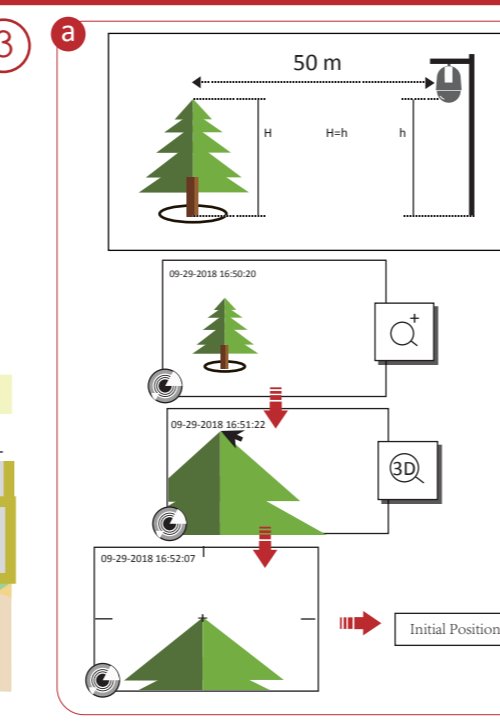
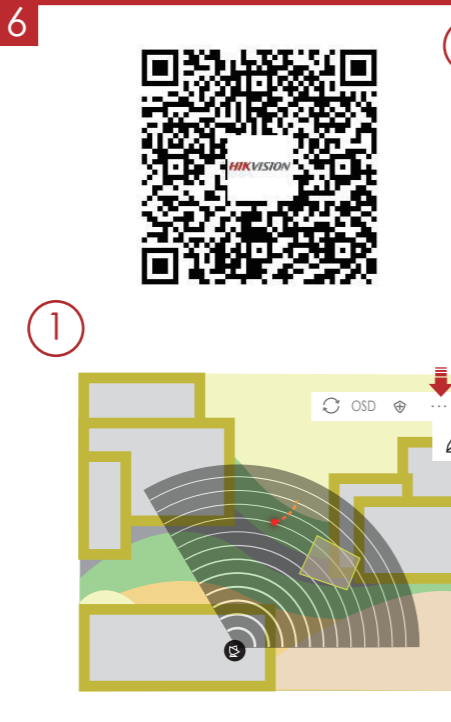
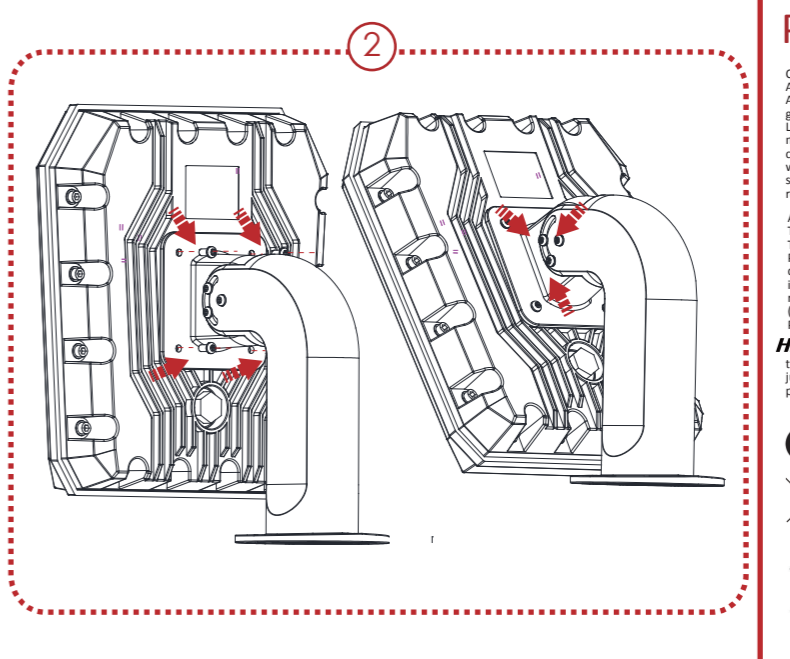
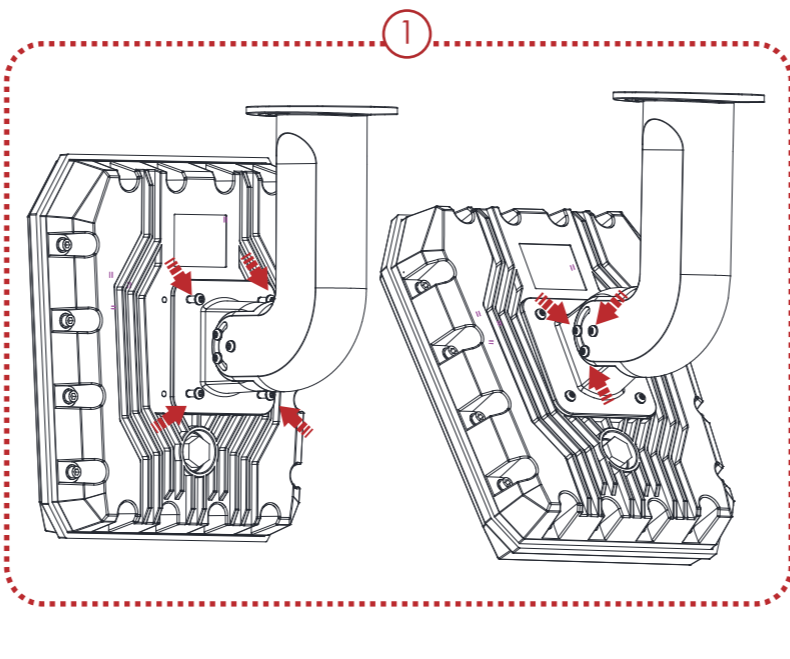
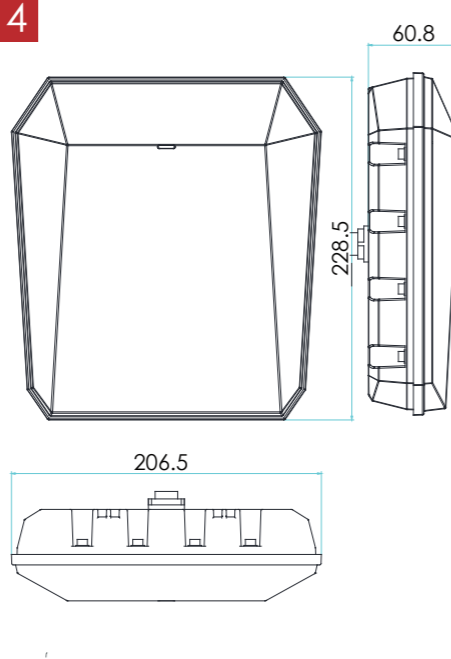
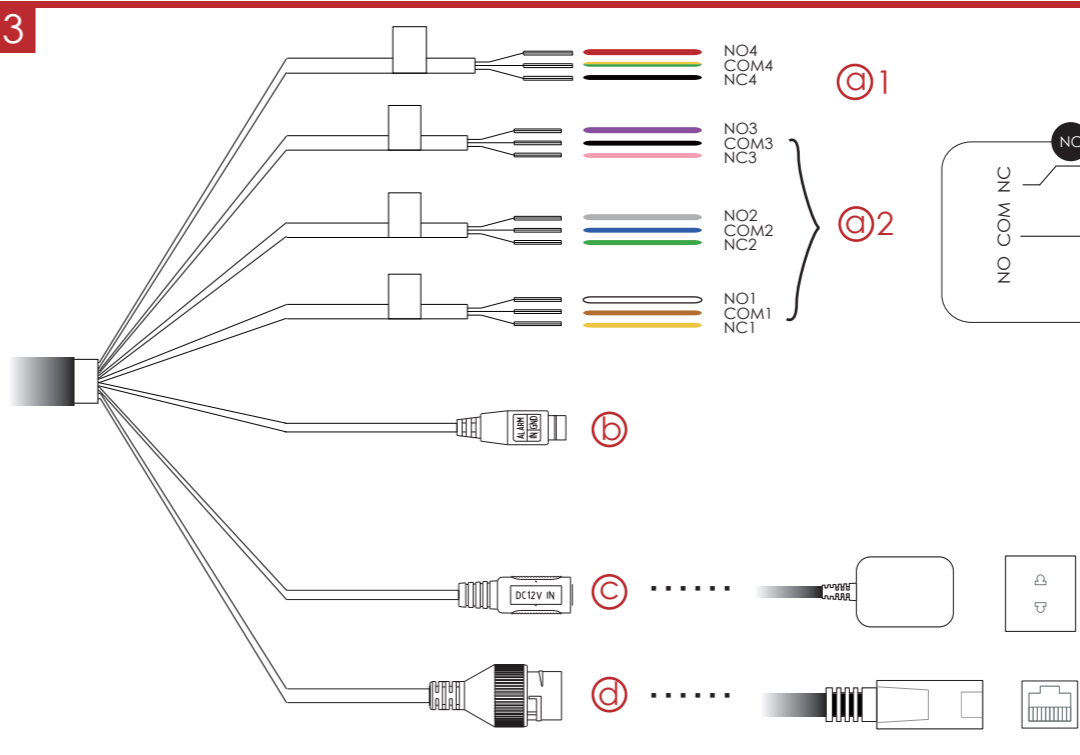
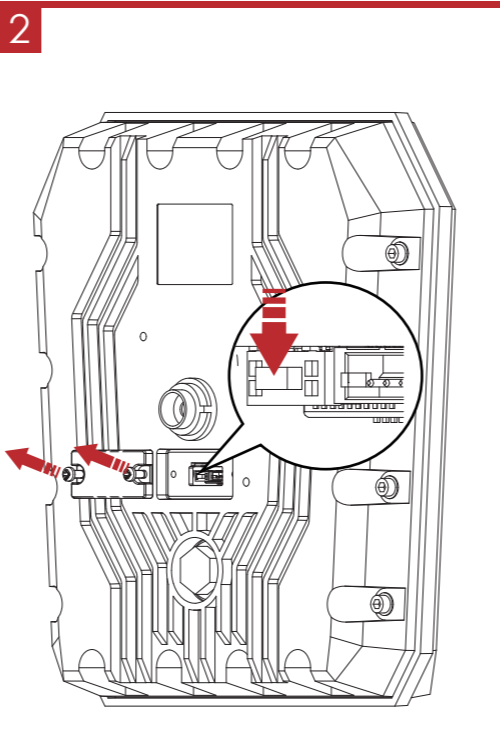
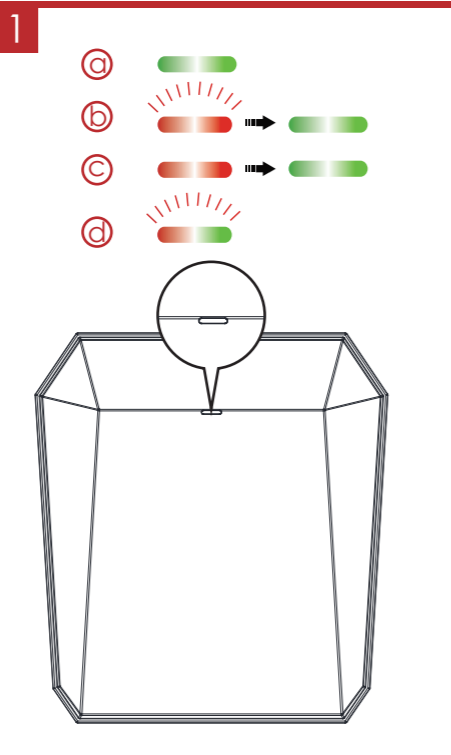

FCC Information

Please take attention that changes or modification not expressly approved by the party responsible for compliance could void the user's authority to operate the equipment.
FCC Compliance: This equipment has been tested and found to comply with the limits for a Class B digital device, pursuant to part 15 of the FCC Rules. These limits are designed to provide reasonable protection against harmful interference in a residential installation. This equipment generates, uses and can radiate radio frequency energy and, if not installed and used in accordance with the instructions, may cause harmful interference to radio communications. However, there is no guarantee that interference will not occur in a particular installation. If this equipment does cause harmful interference to radio or television reception, which can be determined by turning the equipment off and on, the user is encouraged to try to correct the interference by one or more of the following measures:
—Reorient or relocate the receiving antenna.
—Increase the separation between the equipment and receiver.
—Connect the equipment into an outlet on a circuit different from that to which the receiver is connected.
—Consult the dealer or an experienced radio/TV technician for help.
This equipment should be installed and operated with a minimum distance 20cm between the radiator and your body.
FCC Conditions
This device complies with part 15 of the FCC Rules. Operation is subject to the following two conditions:
1. This device may not cause harmful interference.
2. This device must accept any interference received, including interference that may cause undesired operation.

IC Information

Industry Canada ICES-003 Compliance
This device meets the CAN ICES-3 (B)/NMB-3(B) standards requirements.
Industry Canada ICES-003 Compliance
This device meets the CAN ICES-3 (B)/NMB-3(B) standards requirements.
This device complies with Industry Canada licence-exempt RSS standard(s). Operation is subject to the following two conditions:
(1) this device may not cause interference, and
(2) this device must accept any interference, including interference that may cause undesired operation of the device.
Le présent appareil est conforme aux CNR d'Industrie Canada applicables aux appareils radio-exemptés de licence. L'exploitation est autorisée aux deux conditions suivantes:
(1) l'appareil ne doit pas produire de brouillage, et
(2) l'utilisateur de l'appareil doit accepter tout brouillage radioélectrique subi, même si le brouillage est susceptible d'en compromettre le fonctionnement.
Under Industry Canada regulations, this radio transmitter may only operate using an antenna of a type and maximum (or lesser) gain approved for the transmitter by Industry Canada. To reduce potential radio interference to other users, the antenna type and its gain should be so chosen that the equivalent isotropically radiated power (e.i.r.p.) is not more than that necessary for successful communication.

Conformément à la réglementation d'Industrie Canada, le présent émetteur radio peut fonctionner avec une antenne d'un type et d'un gain maximal (ou inférieur) approuvé par l'émetteur par Industrie Canada. Dans le but de réduire les risques de brouillage radioélectrique à l'intention des autres utilisateurs, il faut choisir le type d'antenne et son gain de sorte que la puissance isotrope rayonnée équivalente (p.i.r.e.) ne dépasse pas l'intensité nécessaire à l'établissement d'une communication satisfaisante.

This equipment should be installed and operated with a minimum distance 20cm between the radiator and your body.
Cet équipement doit être installé et utilisé à une distance minimale de 20 cm entre le radiateur et votre corps.

Product Information

COPYRIGHT ©2019 Hangzhou Hikvision Digital Technology Co., Ltd. ALL RIGHTS RESERVED.
Any and all information, including, among others, wordings, pictures, graphs are the properties of Hangzhou Hikvision Digital Technology Co., Ltd. or its subsidiaries (hereinafter referred to be "Hikvision"). This user manual (hereinafter referred to be "the Manual") cannot be reproduced, changed, translated, or distributed, partially or wholly, by any means, without the prior written permission of Hikvision. Unless otherwise stipulated, Hikvision does not make any warranties, guarantees or representations, express or implied, regarding to the Manual.

About this Manual
This Manual is applicable to the Security Radar.
The Manual includes instructions for using and managing the product. Pictures, charts, images and all other information hereinafter are for description and explanation only. The information contained in the Manual is subject to change, without notice, due to firmware updates or other reasons. Please find the latest version in the company website (<http://overseas.hikvision.com/en/>).
Please use this user manual under the guidance of professionals.

HIKVISION Trademarks Acknowledgement and other Hikvision's trademarks and logos are the properties of Hikvision in various jurisdictions. Other trademarks and logos mentioned below are the properties of their respective owners.

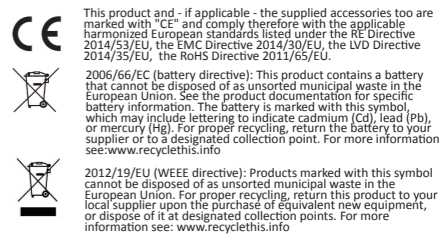

This product operates in a European non-harmonised frequency band.